



Forge Motorsport MK2 Audi TT Twintercooler fitting guide.

If these instructions are unclear in any way then please see <http://www.forgemotorsport.co.uk/content.asp?inc=media> and download the master copy.

Tools required:-vehicle ramp or jack and axle stands, drill and 8.3 or 8.5mm drill bit, T45, T30,T27and T25 torx drivers, 10mm socket/ratchet, 6mm Allen key, Flat blade screwdriver, safety clothing, footwear and eyewear are also recommended.

Raise vehicle and open bonnet/hood. It is necessary to remove the front panel and grill from the front of the vehicle.

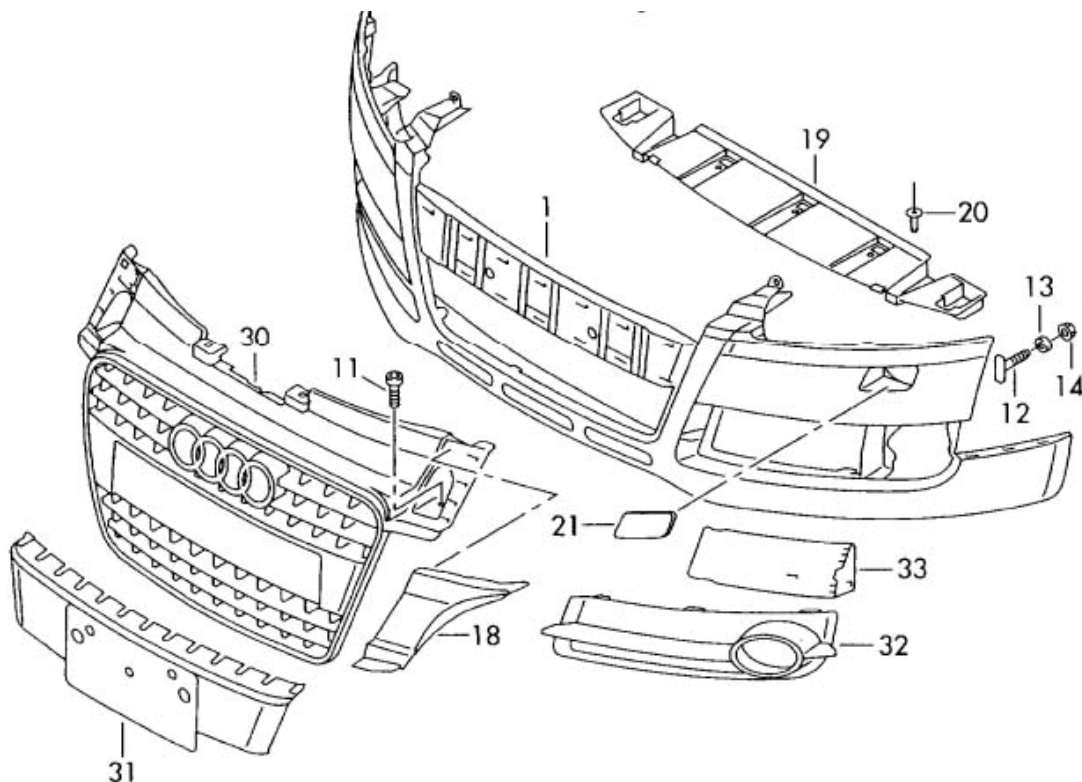
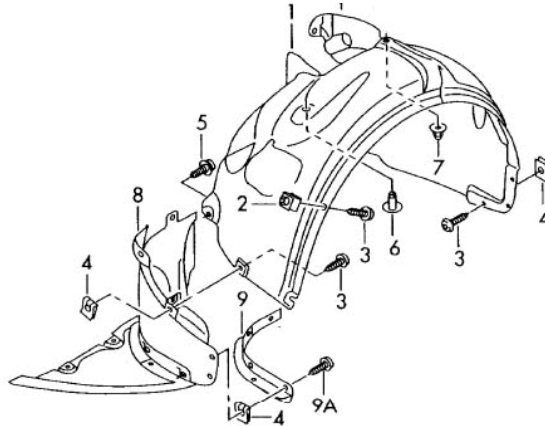

Fig 1



To do this firstly remove the four Torx screws from the lower front edge of both wheel arch liners.



Next remove the undertray from the vehicle. Once the screws have been removed the tray is slid to the rear of the vehicle to free it from where it slots into the lower edge of the front panel (bumper cover)



In order to access the bolts hold the front panel to the front wings it is necessary to remove the headlights. Remove the headlight trim panels, these are clipped on the outer edge and slotted on the inner. Once removed you will see a Torx bolt (No.11 in Fig 1) on each side that requires removal.



Remove the electrical connectors from the rear of the headlight units and remove the upper and one lower torx screws to allow the units to be withdrawn.



With the headlights removed access can now be gained to the two 10mm nuts (No.14 in Fig 1) that secure the front panel to the side wing (fender). As the front panel is withdrawn it will be necessary to disconnect the front fog lights and headlight washers if fitted.



Remove the 2 x radiator air deflectors. (These will not be refitted.) You will also need to remove the temperature sensor from the cowl. This will be relocated.



Remove the polystyrene crash bumper cover. This will be refitted.



Remove both lower standard intercooler hoses; these are just clipped in via a spring clip. Prize this away with a flat end screwdriver to aid removal of the hose end fitting, these will not be refitted but the seals are required later so place to one side for now.

Remove the oil seals from the original intercooler hoses and fit these to the corresponding new aluminium hose couplings as pictured below, these are different sizes so make sure you fit the correct seal to the correct adapter. Fit the hose couplings into the respective fittings on the original intercooler and the turbo outlet pipe on the right side running alongside the engine sump. Make sure the spring clips are located securely to prevent these couplings from being blown out of the fixings under boost.

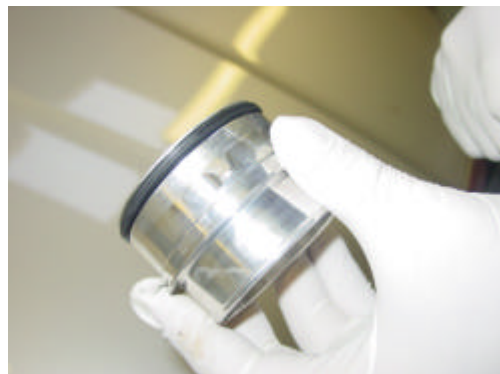

Now fit the new hoses to join all the couplings and make sure they do not foul on any other engine or front panel components. At this stage although the hose clamps should be fitted , do not tighten.



The temperature sensor that was removed from the radiator cowl, should be relocated above the alloy crash bumper onto the horn mounting using the small bracket supplied.

The next task is to install the intercooler into the hoses and centralise its position in relation to the front of the vehicle.





The intercooler requires to be raised enough so that its lower edge clears the lip of the radiator mounting panel thus allowing it to sit flush with the alloy crash bumper. When you are ready to secure the intercooler, drill through the brackets as shown. Although it is prudent to use a smaller diameter drill for a pilot hole, the final diameter should be 8.3 or 8.5mm. The intercooler is then secured using the supplied M8 Allen bolts.



With the intercooler mounted, all the hose clamps require tightening and the polystyrene crash bumper cover is replaced.

Refit the under-tray and bumper, this is a reversal of the removal procedure, not forgetting to reconnect any fog lights or headlight washers if previously disconnected. Refit the headlight units and inner wheel arch liners, again, as a reversal of their removal procedure.

Clear away all tools, close the bonnet/hood and lower the vehicle to the ground. You are now ready to enjoy the new found performance of your vehicle.